

## High Temperature Use Packings

### GRASEAL™ Packing

### TOMBO™ No.2200 and 2205 Series

#### Construction

TOMBO™ No.2200 series is a packing made from expanded graphite (GRASEAL™) cut into strips and shaped into rings in a mold. The packing is treated to give it anti-corrosion features, and is an excellent packing for high temperature / high pressure applications.

We carry TOMBO™ No.2200-P and TOMBO™ No.2200-L models of this packing, each having different types of impregnated lubricant.

The TOMBO™ No.2205 series is a TOMBO™ No.2200 packing with the addition of a stainless steel mesh incorporated into its center so that the packing can be removed easily. Like the TOMBO™ No.2200 series, we carry TOMBO™ No.2205-P and TOMBO™ No.2205-L models.

45 degree bias cut is standard but non-cutting or 2 cutting are also available on request.

#### Features

1. Superior sealing performance compared to asbestos products.
2. Little differences in performance from cryogenic to high temperatures.
3. Expanded graphite (GRASEAL™) has chemical resistance properties second only to PTFE, and can be used with almost any fluid (with the exception of those listed below).
4. Less shrinkage at high temperatures than asbestos packings, with little stress relaxation.

#### Service Range

|                  |  |
|------------------|--|
| Max. Temperature | – 240 ~ 400°C (oxidizing atmosphere, in air)               |
|                  | – 240 ~ 1650°C (non-oxidizing atmosphere)                  |
| Max. Pressure    | 43MPa  |
|                  | (when used with a TOMBO™ No.2250 or other adapter packing) |
| Pressure Class   | 4500   |

#### Application

Thermal power plants, petroleum refineries, shipbuilding, chemical plants, cryogenic services, high temperature gas plants, etc.

Cast steel valves, forged steel valves, stainless steel valves, etc.

#### Fluids

Water type fluids (water, hot water, steam, etc.), oil type fluids (oil, heat transfer oil, etc.), organic solvents, hydrocarbons, gaseous fluids (hydrogen, ammonia, etc.), chemical products, corrosive fluids (other than oxidizing fluids), and cryogenic fluids (LN<sub>2</sub>, liquid air, LNG, LPG, etc.).

#### ⚠ Not applicable

| Type                     | Fluid name  |
|--------------------------|---|
| Oxidizing acids          | Nitric acid, concentrated sulphuric acid, hot sulphuric acid, mixed acids, chromic acid, etc. |
| Oxidizing salts          | Nitrate, chlorate, hypochlorite, etc.   |
| Halogen compounds        | Bromine, fluorine, iodine, chlorine dioxide, etc.   |
| Combustion promoting gas | Oxygen (pure oxygen)  |

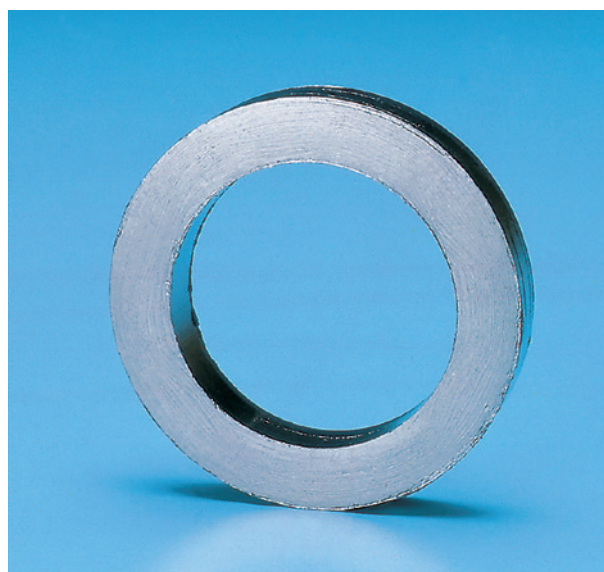

TOMBO™ No.2205-P

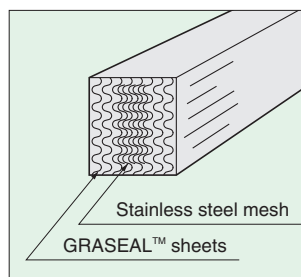

Fig. 1 TOMBO™ No.2205 Cross-section

- For packings with cross-sectional dimensions of less than 4 mm, stainless steel mesh is not incorporated.

#### Standard Dimensions

The TOMBO™ No.2200 series, TOMBO™ No.2205 series, TOMBO™ No.2250, and TOMBO™ No.2930 products are ring form.

The TOMBO™ No.2200 series, TOMBO™ No.2205 series, and TOMBO™ No.2930 products are normally manufactured with a single 45 degree bias cut, and the TOMBO™ No.2250 is normally manufactured with a single straight cut.

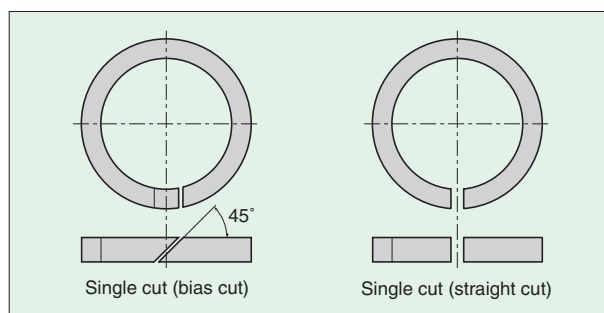

Fig. 2 Cutting Method

#### Ordering Information

Please specify the ring ID, OD, height, and number of packings. Please order TOMBO™ No.2250 and TOMBO™ No.2930 (etc.) adapter packings along with TOMBO™ No.2200 series and TOMBO™ No.2205 series packings.